

Fusion Power Multiplier Installation Manual *Introduction and Overview*

The diyhighsupply® Fusion Power Multiplier Module has been designed to offer a State of the Art Power Boosting for low power Tube Amplifiers and other Tube based amplification stages.

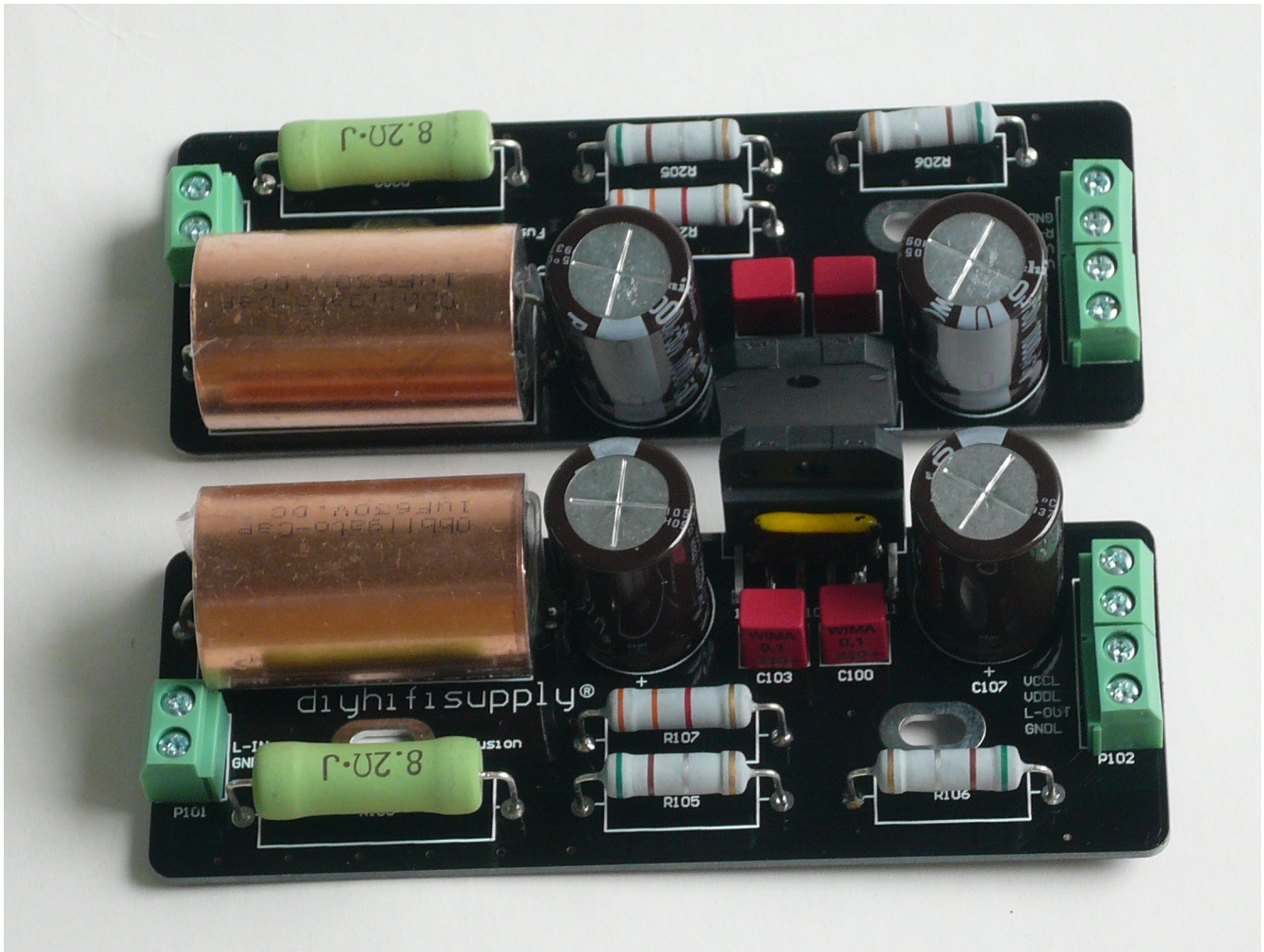

Additional applications include the use as with 20dB gain to complement the Universal Tube Output Stage.

The Fusion Power Multiplier Module can be connected singly for loads down to 4 Ohm or in multiples in parallel for lower impedances. With a suitable drive system even balanced bridge and parallel connection is possible.

Using a pair of modules, a suitable driving amplifier or tube stage and a suitable powersupply we have hybrid amplifier of the highest quality able to deliver 40W into 8 Ohm and 65 W into 4 Ohm loads.

When using multiple modules and a suitable driver stage as well as power supply the output power can scale up to 160W into 8 Ohm .and 260W into 4 Ohm.

Fusion Power Multiplier Installation Manual

For ease of application all connections on the Fusion Power Multiplier Module are provided as screw terminals, so no soldering is required on the Fusion Power Multiplier Module.

For those desiring soldered connections instead we recommend to either unsolder the screw terminals and solder the wires in the holes thus available or to simply solder the wires to the solder pads below the PCB.

The Fusion Module protects itself against overload, overheating and a short circuit of the output to ground. Care must be taken to not short the output to one of the power supply connections and to not exceed the maximum DC voltage per power supply (+/- 42V).

In the following Manual the application of the Fusion Power Multiplier Module is broken down into three distinct sections. Section one covers the Powersupply of the Module.

Section two describes the connections of the module using a conventional SE or PP Amplifier while section three covers the connections of the module to low power tube stages (requires modifications to the Fusion Module).

1 – Power Supply

The Fusion Module needs a power supply of +/- 35V. We recommend the following schematic for making a suitable supply. The Power Transformer should be at least 160VA and have two separate windings of 0-22V to 0-25V. Voltages higher than 25V AC nominal from the Mains transformer MUST not be used.

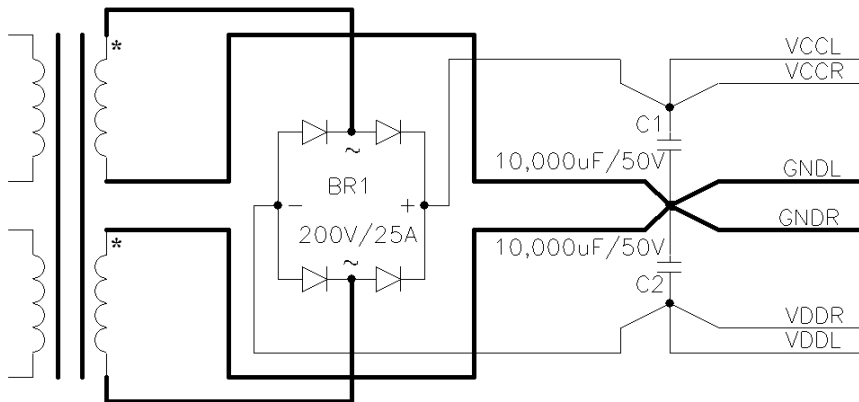

While the Fusion Module will protect itself from most problems (like output short circuit to ground) exceeding the power supply voltage will damage it. Using a Mains transformer with the correct primary voltage for your local voltage with secondary windings not exceeding 25V will guarantee this.

Fusion Power Multiplier Installation Manual

2 – General Application Notes

The Fusion Modules need to be mounted to a substantial heatsink to operate correctly. Large aluminium chassis such as used in the diyhifisupply amplifier kits usually suffice. The heatsink should have a large flat area where the chip is mounted.

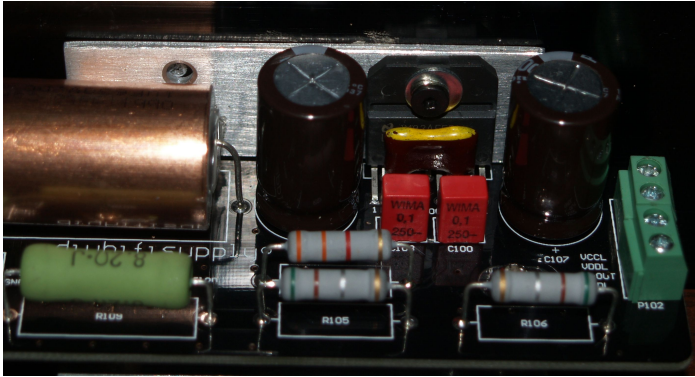

As the actual power amplifier chip is fully isolated no isolation is required. However some form of heat transfer compound should be used between chip and heatsink. The modern types of heat transfer compound developed for computer CPU's are usually a better choice than the "white goo" commonly used in electronics.

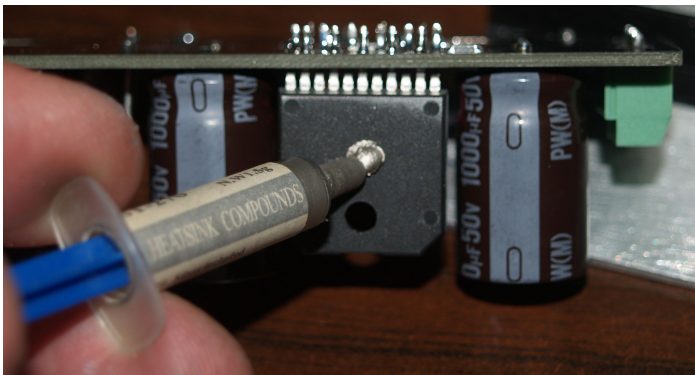

For mounting please use a screw with a large washer and a spring washer, this makes sure the connection to the heatsink remains tight.

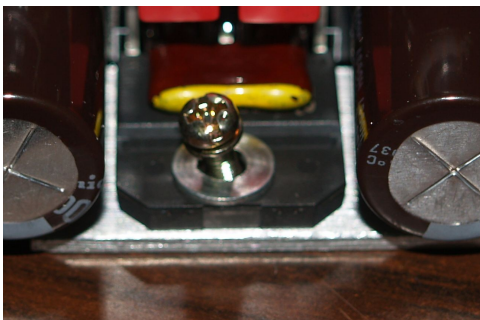

Fusion Power Multiplier Installation Manual

2 – Wiring for Fusion PCB in Standard Mode

The Fusion module was originally designed as “reheat” system for conventional SE Amplifiers. (“reheat” is the Air-Force term for afterburner use in jet engines).

Shown below are the connections that need to be made to each Fusion module when using it as simple “Power Multiplier” for existing SE Amplifiers:

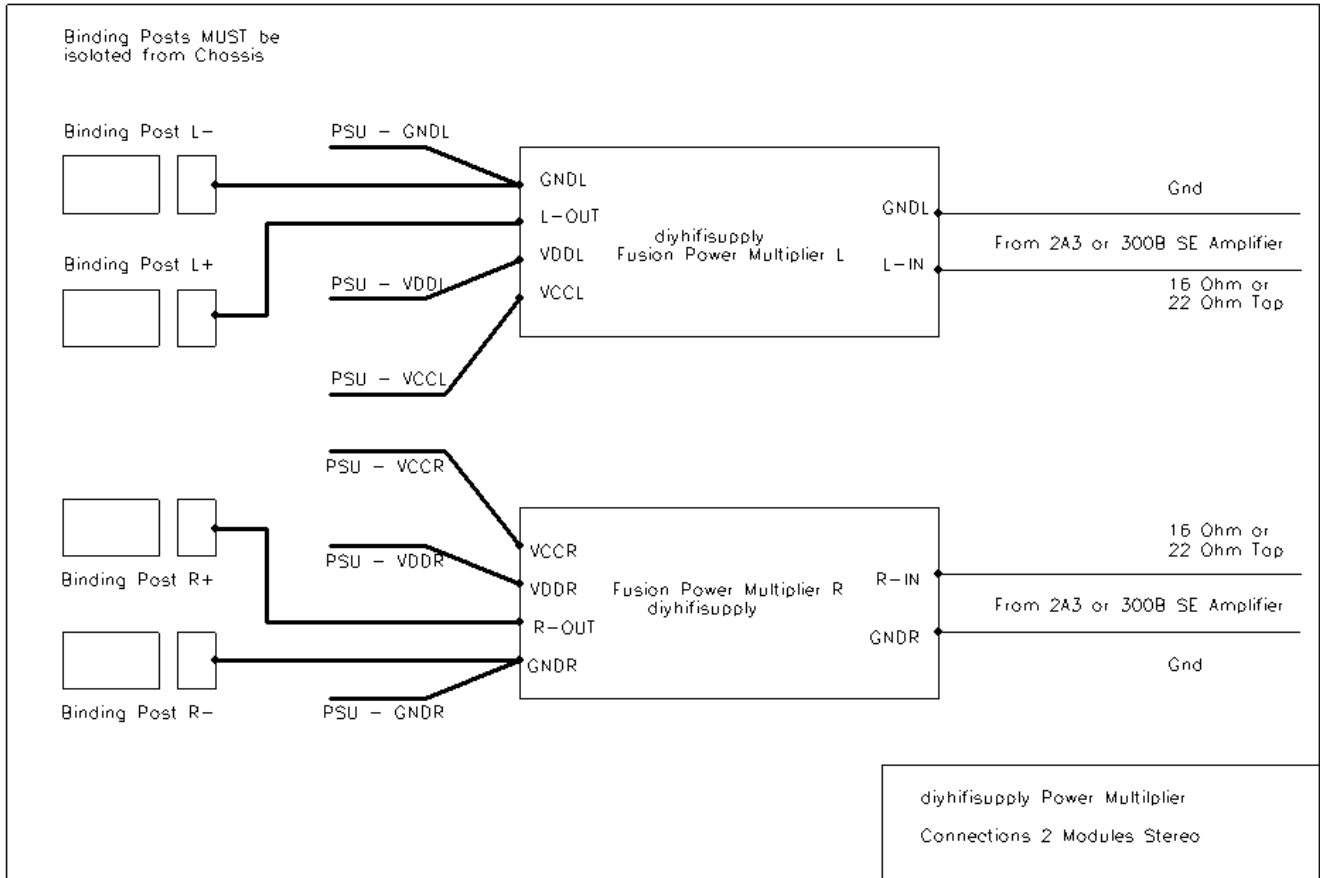

In order to get the full power available from the Fusion module the output of the amplifier must be equipped with a 16 Ohm (or higher) connection. When used with the 16 Ohm connection from a typical SE Amplifier the Fusion Module can provide around four time the power of the original Amplifier into 8 ohm and up to eight times the original power but no more than around 65Watt into 4 Ohm. So a 4-5 Watt 2A3 Amplifier equipped with a 16 Ohm Tap can produce 16 to 20 Watt power into an 8 ohm speaker and 32 – 40 Watt into a 4 Ohm speaker. An 8 – 10 Watt 300B Amplifier with a 16 Ohm connection and helped by the Fusion Module in turn can produce 32 – 40 Watt into an 8 ohm speaker and around 65 Watt into a 4 Ohm one.

When using the 8 Ohm output connection the Fusion buffer can still help boost the power, however maximum available power is not reached. With an 8 Ohm input connection power is about doubled into 8 Ohm and quadrupled into 4 Ohm. Hence the Fusion buffer can be useful in even these cases especially if the Speaker has a low (4 Ohm or lower) impedance.

Fusion Power Multiplier Installation Manual

If only an 8 ohm input connection is available and the speaker have very low impedance the power supply should use a mains transformer with 18V windings instead or the 22-25V windings recommended as this allows speaker that drop significantly below 4 Ohm impedance can be driven better.

3 –Wiring for Fusion PCB as Standard Hybrid Amplifier Power Buffer

While designed with a clever twist of circuit topology to avoid the shortcomings of classic hybrid amplifiers, a simple modification can disable the “Fusion Multiplier” and turn the fusion module into a simple Class AB power Buffer. It can then be used with traditional Tube gain stages that cannot provide any significant output current.

To do this remove R109 on the Left channel board and R209 on the Right channel board. This resistor normally governs the amount current drawn from the driving amplifier. Using this the input impedance of the Fusion Module becomes 47 KOhm and no connection exists between speaker and tube stage. Shown below are the connections that need to be made to each Fusion module when using it as unity gain buffer:

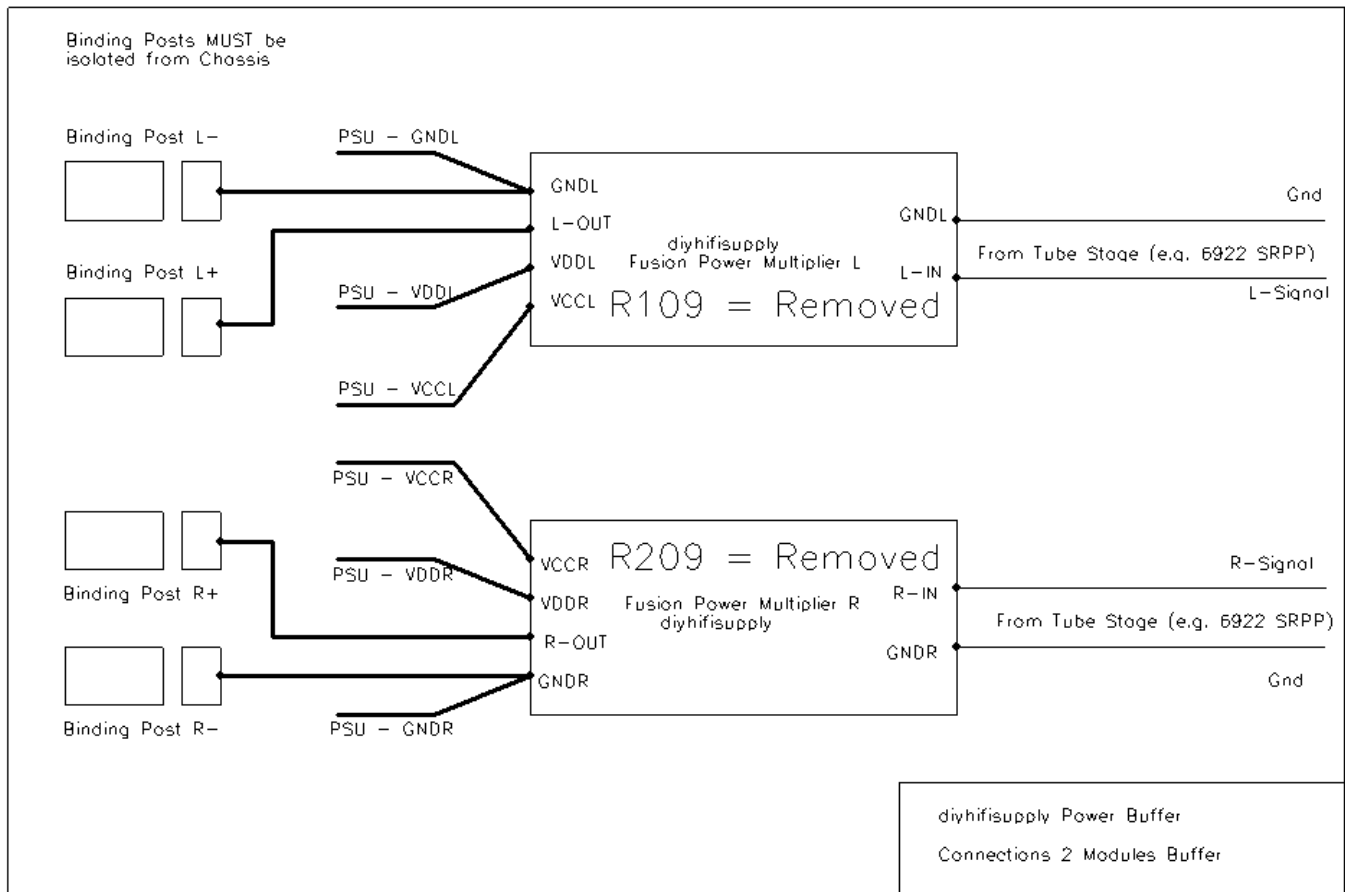

Please note that this setup is quite challenging to implement and not really suited to beginners and inexperienced DIY'ers. The technical support we can give for this implementation is extremely limited.

Fusion Power Multiplier Installation Manual

4 –Wiring for Fusion – UTS Special PCB

For those of the diyhifisupply customers that would like to build a hybrid amplifier using our Universal Tube Stage (UTS) and the Fusion module, a special version of the Fusion module is available. This version is not a unity gain buffer, but has a certain amount of gain implemented to provide the match with the Universal Tube Stage. This is necessary as the UTS was designed for line levels of 2...5V RMS and cannot produce the 16V RMS needed to drive the Fusion Module to full power.

Note that the Fusion Module **MUST** be ordered as *UTS Special* version. The standard Fusion Module cannot be employed! We do not support conversion of the Fusion Module by customers, due to the difficulty of modifying assembled modules and due to the need for SMD soldering.

Shown below are the connections that need to be made between Fusion module and UTS Module:

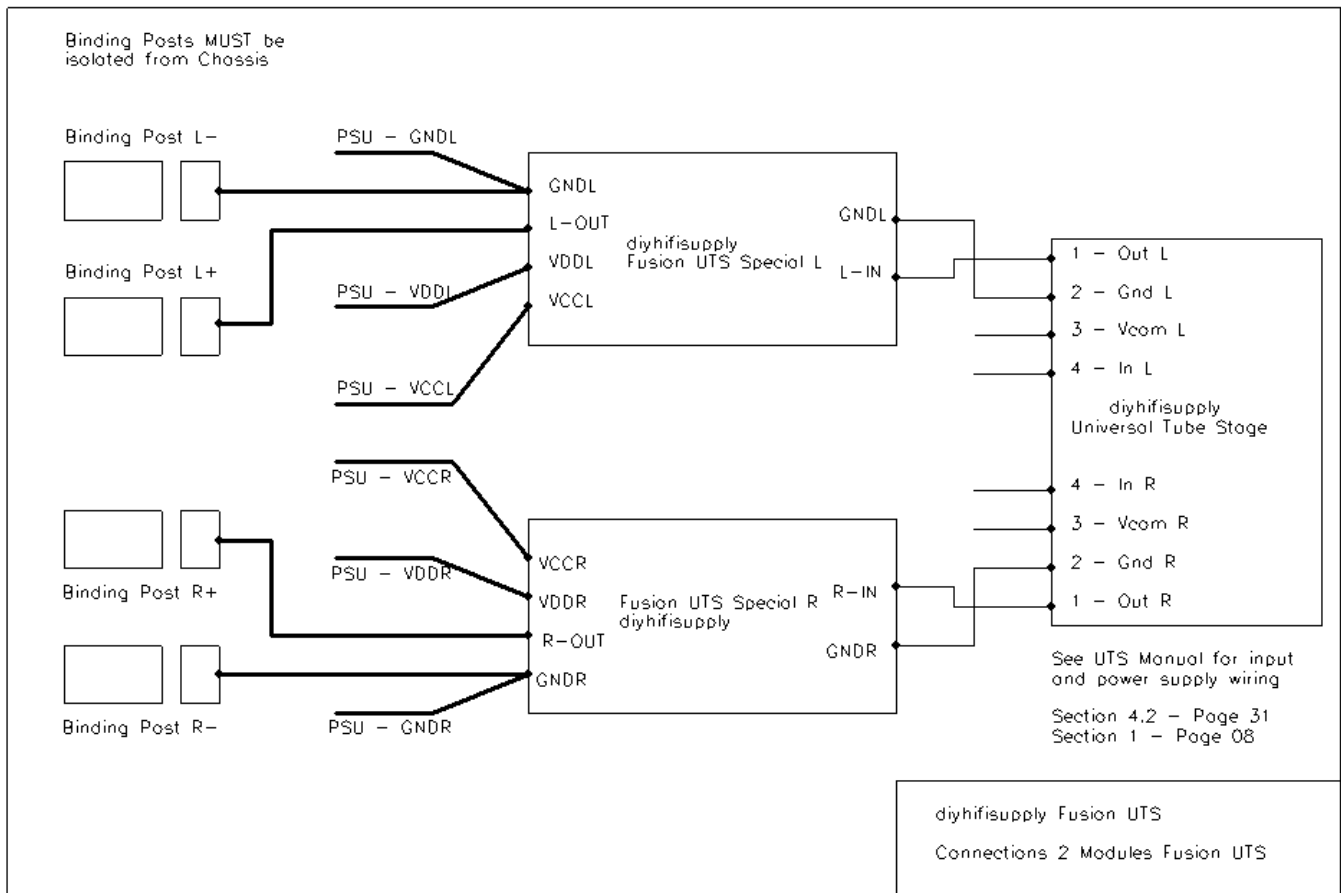

All other connections to the UTS are the same as found in the Universal Tube Stage Installation manual, sections 1 – *Power Supply Wiring* on Page 8 and 4.2 – *Settings and Input wiring for use as SE Linestage 12db Gain* on page 31 respectively.

For convenience these sections are reproduced on the next pages.

Fusion Power Multiplier Installation Manual

4.1 – UTS Power Supply Wiring

If your local power supply is in the range of 100V to 120V AC wire up the mains transformer as shown below.

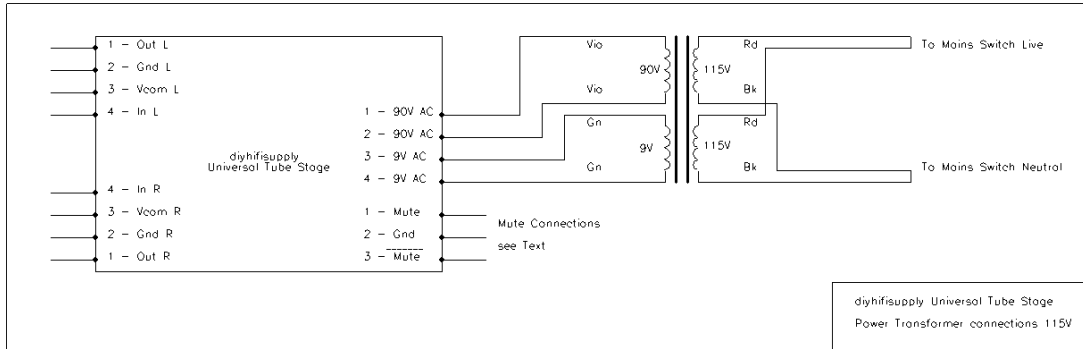

If your local power supply is in the range of 220V to 240V AC wire up the mains transformer as shown below.

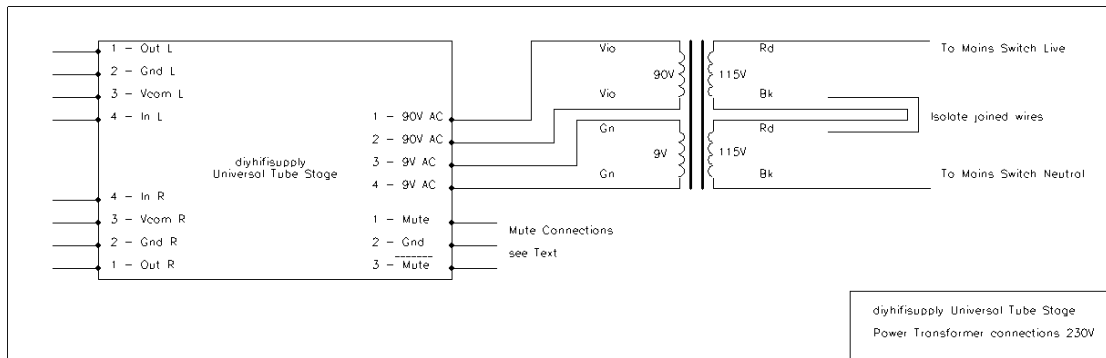

4.2 – UTS Settings and Input wiring for use as SE Linestage 12db Gain

This type of Application requires the following jumper settings:

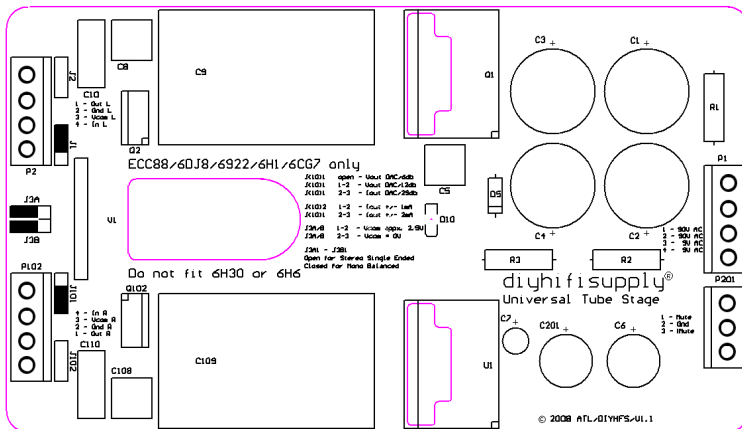

The input connections should follow the Scheme shown underneath:

Fusion Power Multiplier Installation Manual

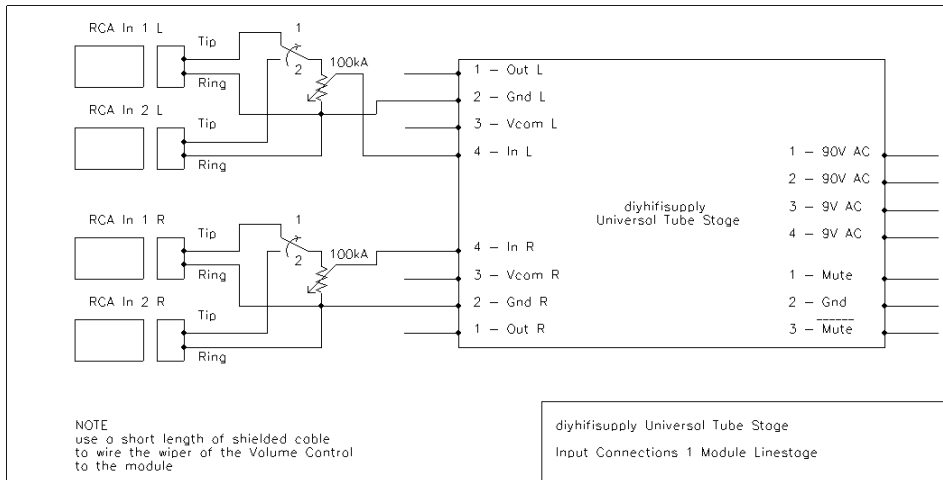

5 –Wiring Four Fusion PCB’s for high power

If it is possible to either make a special single ended amplifier with a custom made output transformer that can deliver 32V RMS or suitable stepup transformer can be used (1:4 is recommended with a 2A3 Amplifier having a 16 Ohm Tap) it is possible to use the Fusion modules in sets of four per channel. This provides up to 160 Watt into 8 Ohm and 260 Watt into 4 Ohm, depending on the size of the power supply and the exact setup. Such power levels should suffice even for the lowest efficiency Speakers in larger rooms.

When using this scheme it will be necessary to replace the 8.2Ohm Resistor (R109/R209) with 33 ohm 1 Watt types. This resistor sets the load presented by a single Fusion module input to around 30 Times that of the Speaker load in the original with 8.2 Ohm. Combined with the transformer stepup this would likely load both amplifier and step-up transformer too much. Using a 1:4 stepup transformer and four modules using $R_{x09} = 33$ Ohm with a 4 Ohm speaker will load the driving amplifier with 35 Ohm and with around 68 Ohm for an 8 Ohm Speaker.

The stepup transformer needs to have a 5600 ohm secondary and handle a level of +32dBu on this winding. Some Studio Line transformers offer suitable parameters, however most often it will be necessary to commission a custom design. This transformer should use a permalloy core, likely standard Radiometal or similar types with around 50% Nickel will suffice.

Instead it may be easier to commission a custom output Transformer for the SE Amplifier with an added “32V” / 600 Ohm winding. It may even be possible to retain a further winding that allows direct drive to speakers.

Fusion Power Multiplier Installation Manual

Below is shown the necessary wiring (excluding the power supply connections) with the stepup transformer option shown. Note the secondary of the output or stepup transformer is center tapped and the center tap is connected to the Fusion module's ground.

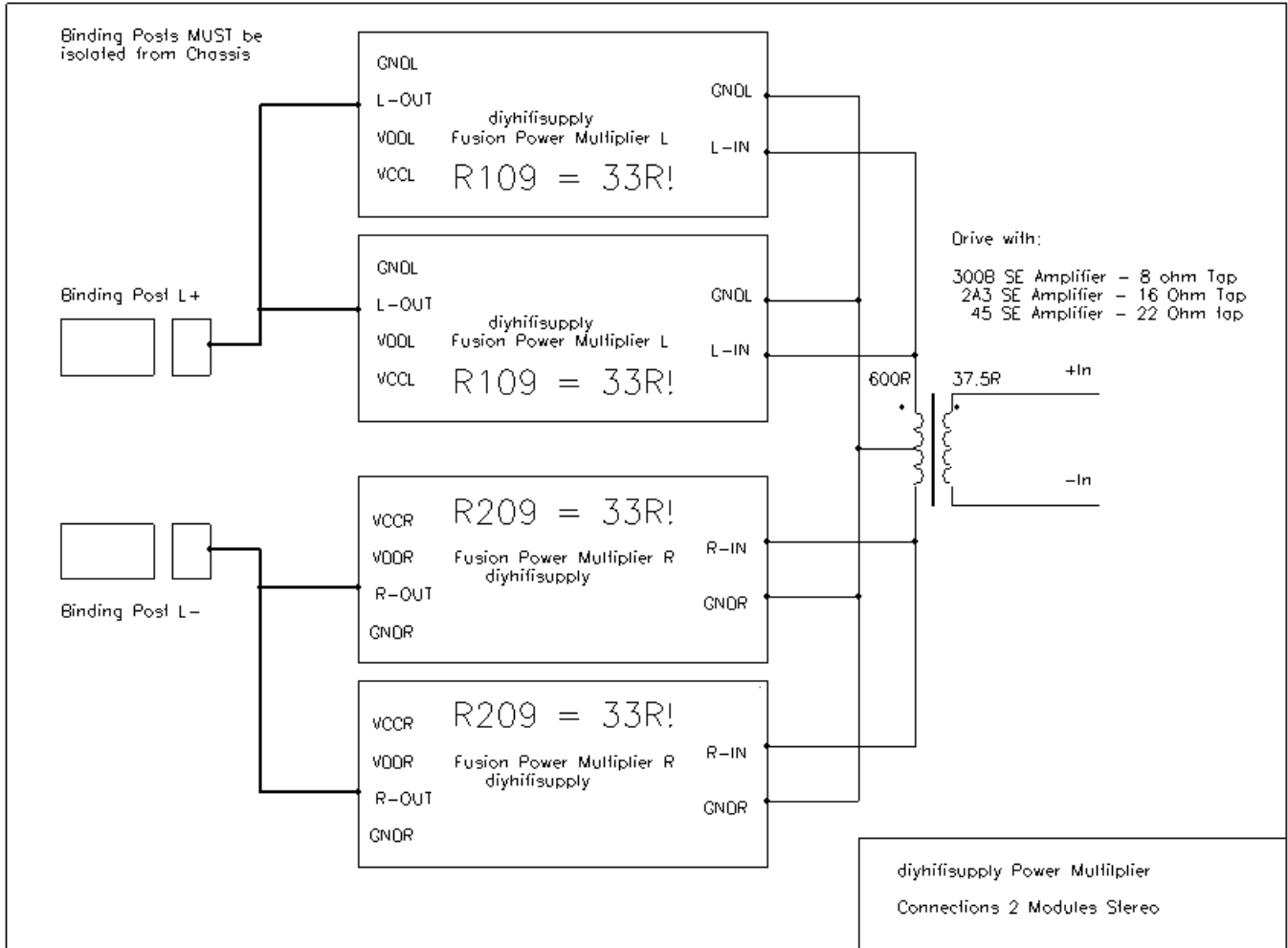

The Powersupply connections follow the wiring shown in 2 and hence is not repeated.

Please note that this setup is quite challenging to implement and not really suited to beginners and inexperienced DIY'ers. The technical support we can give for this implementation is extremely limited.